



DRY RUN & VERTICAL PUMP (IN & OUT-TANK TYPE)

可空轉直立式耐酸鹼泵浦(可槽內外使用)

KUOBAO

KDH series

特點：

1. 採用高效率鋁合金馬達絕緣等級F級及泵浦本體連接座，採用FRPP材質，不僅大大減輕泵浦機體重量，更能有效防止酸氣侵蝕。
2. 乾式液封可確保防止馬達及軸承被化學氣體浸蝕，延長馬達及泵浦之使用壽命。泵浦本體所採用FRPP, CFRPP及PVDF材質，具有耐高溫、耐腐蝕之特性。
3. 採無焊接點及出入口為活動式法蘭設計，易於安裝及日後維修等特性。
4. 前蓋無螺絲設計，適用於任何環境下使用，獨特具有高揚程、高壓力、高效率等特性。
5. 適用於蝕刻噴洗設備，廢氣洗滌塔、冷卻循環及搭配過濾機使用。
6. 本泵浦可無水空運轉使用，絕不會損壞。

FEATURES :

www.KUOBAO-intl.com.tw

1. Due to the FRPP material of pump body's connected holder and effective aluminum motor of insulation class F, they make not only the weight of motor lighter but also acid corrosion resistance stronger.
2. Thanks to the dry vapor seal, it prolongs the using life of pump and avoids motors and bearings being etched by chemical gas. The FRPP, CFRPP and PVDF material of pump body is provided with high temperature sustain and corrosion resistance.
3. One piece injected without welding and in-outlet moveable flanges lead us to install and maintain easily.
4. Front covers without screws design have unique high head, high pressure and high efficiency, and apply to all kinds of environments.
5. Apply to etching equipments, wasted gas washing towers, circulated cooling systems and assort with chemical filters.
6. No damaged in the dry operation without water.

KDH series

DRY RUN & VERTICAL PUMP (IN & OUT-TANK TYPE)
可空轉直立式耐酸鹼泵浦(可槽內外使用)

型號說明 MODEL IDENTIFICATION

KDH - 50 - VK - 5 - 6 - V - F - H
 ① ② ③ ④ ⑤ ⑥ ⑦ ⑧

1. 機型編號 MODEL : KDH
2. 口徑 IN-OUTLET : 50-2" 65-2-1/2" 80-3"
3. 比重 SPECIFIC WEIGHT : VK-1.1 VP-1.4
4. 馬力 POWER : 3, 5, 7.5, 10HP
5. 頻率 FREQUENCY : 5-50HZ 6-60HZ
6. 橡膠材質 RUBBER : N-NBR E-EPDM V-VITON
7. 泵體材質 MATERIAL : F-FRPP C-CFRPP P-PVDF
8. H-高揚程

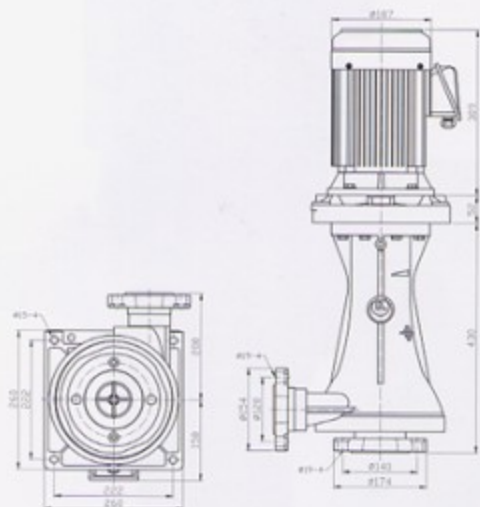

性能曲線圖 PERFORMANCE CURVE CHART

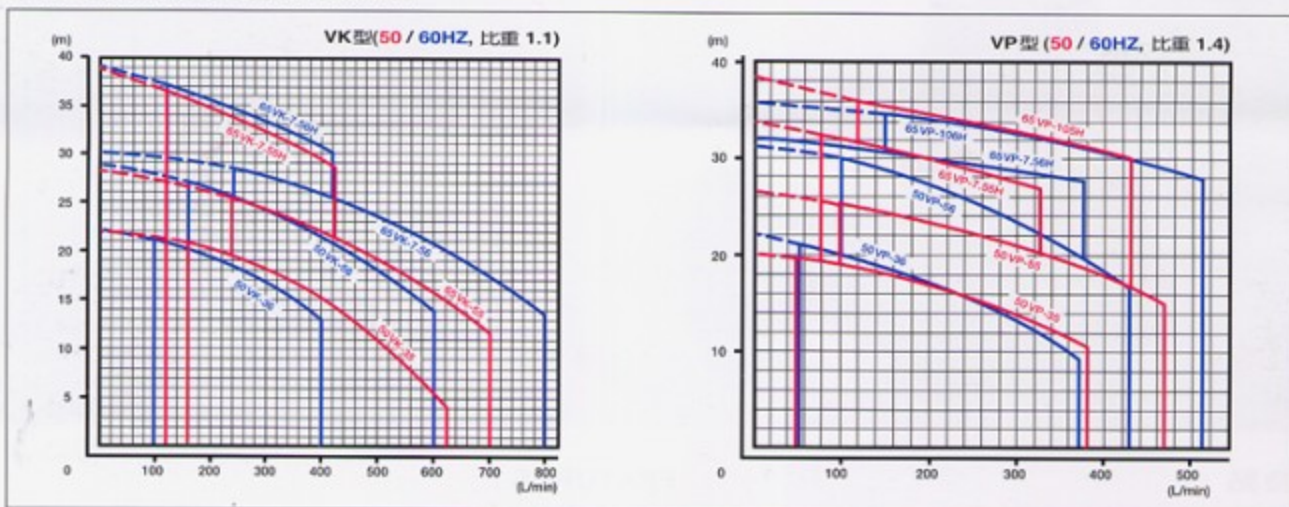

型式	口徑 In / Outlet (mm)		馬力 Motor (HP)	揚程 Head (M)		流量 Capacity (L/min)	
	入口 IN	出口 OUT		50Hz	60Hz	50Hz	60Hz
KDH-50VK-3	65	50	3	12	12	350	350
KDH-50VK-5	65	50	5	-	15	-	550
KDH-65VK-5	80	65	5	15	-	550	-
KDH-65VK-7.5	80	65	7.5	-	20	-	600
KDH-65VK-7.5-H	80	65	7.5	30	30	400	400
KDH-50VP-3	65	50	3	12	12	300	300
KDH-50VP-5	65	50	5	16	16	400	400
KDH-65VP-7.5-H	80	65	7.5	28	28	300	300
KDH-65VP-10-H	80	65	10	30	30	400	400